

# SMART Board™ Interactive Whiteboard

## Specifications – Model 690

### Physical Specifications

<b>Size of Interactive Whiteboard</b>	85 3/4" W x 49 1/2" H x 5 1/8" D (217.8 cm x 125.7 cm x 13.0 cm)
<b>Active Screen Area</b>	82 1/8" W x 46 1/8" H (208.6 cm x 117.2 cm) 94 1/4" diagonal (239.3 cm) 16:9 aspect ratio
<b>Weight</b>	48 lb. (21.8 kg)
<b>Shipping Size</b>	
1 unit	54" W x 94 1/2" H x 5 1/2" D (137.2 cm x 238.8 cm x 14.0 cm)
8 units on pallet	55" W x 99" H x 45" D (139.7 cm x 251.5 cm x 114.3 cm)
<b>Shipping Weight</b>	
1 unit	59 lb. (26.8 kg)
8 units on pallet	492 lb. (223.6 kg)

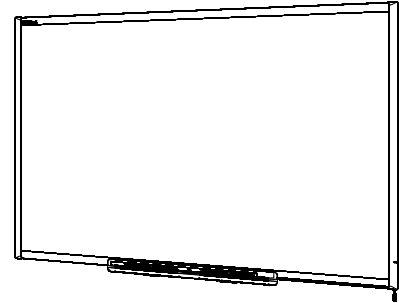

All dimensions +/- 1/8" (3.2 mm). All weights +/- 2 lb. (0.9 kg).

### Standard Features

<b>Software</b>	SMART Board™ software, including Notebook™ software. Upgrades are available at <a href="http://www.smarttech.com/support/software/index.asp">www.smarttech.com/support/software/index.asp</a> .
<b>Pen Tray</b>	Optical sensors in the pen tray detect when a pen or eraser is lifted from the tray. LEDs show the active tool.
<b>Pens and Eraser</b>	Black, blue, red and green pen tray pens and a rectangular eraser
<b>Resolution</b>	Touch resolution is approximately 4000 x 4000.
<b>Screen Surface</b>	The hard-coated polyester surface is tear proof, optimized for projection, compatible with dry-erase markers and is easily cleaned with whiteboard cleaner.
<b>Digitizing Technology</b>	Analog resistive
<b>Frame Finish</b>	Two-tone gray (approximates Pantone® Charcoal Gray 18-0601 TPX) and Ultrasonic Chrome (approximates metallic Pantone 877 C)
<b>Wall-Mount Bracket</b>	2 x 32" (81.3 cm) wide, spaced 2" (5.1 cm) apart, with ten screws and drywall anchors to support the wall-mounted interactive whiteboard
<b>Computer Connection</b>	16' (5 m) USB 2.0 cable
<b>Power Requirements</b>	Power is obtained from the computer directly through the USB cable for Windows®, Mac and Linux® computers. Power consumption is less than 1.5 W (300mA at 5V).
<b>Certifications and Compliance</b>	CSA (Canada/U.S.), CE, CB (TUV), RoHS (China), RoHS (Europe), WEEE
<b>Warranty</b>	Five-year limited equipment warranty upon registration. See warranty document for details.

**NOTE:** A digital projector is not included with this model of SMART Board interactive whiteboard. To take full advantage of all interactive features, you must integrate a 16:9 aspect ratio digital projector.

---

## SMART Board Software 9.7 Computer Requirements

<b>Windows Computers</b>	Pentium® II 450 MHz processor 128 MB of RAM (256 MB recommended) 150 MB of free hard disk space for minimum installation (840 MB for full installation with Gallery collections) Windows 2000, Windows XP or Windows Vista™ operating system Internet Explorer® internet browser 6.0 or later Adobe® Flash™ player version 8
<b>Requirements for SMART Video Player</b>	Pentium II 450 MHz processor (700 MHz or faster recommended) Windows 2000 operating system or later Microsoft® DirectX® technology 8.1 or later
<b>Mac Computers</b>	700 MHz processor (1 GHz or faster recommended) 128 MB of RAM (256 MB recommended) 75 MB of free hard disk space for minimum installation (930 MB for full installation with Gallery collections) Mac OS X version 10.4.x operating system software Safari application program version 1.3.2 or later SMART Board software version 9.7 supports both PowerPC® and Intel® processors (universal binary)
<b>Linux Computers</b>	Pentium II 450 MHz processor 128 MB of RAM (256 MB recommended) 225 MB of free hard disk space for minimum installation (800 MB for full installation with Gallery collections) Linux kernel version 2.6 or later X Window System™ version 11 release 6 (X11R6) or later (must support XRender, Xinerama™, XFixes, Xau and Xdmcp) glibc 2.3.3 (gcc 3.4.2) libstdc++6 GNOME™ 2.8.0+ or KDE® 3.3+ libraries (recommended) SUSE™ 10, Red Hat® Enterprise Linux 4 WS, Debian® 3.1 (Sarge), Ubuntu® 6.06 LTS or Fedora™ Core 3+

---

## Storage and Operating Specifications

<b>Storage</b>	-40°F to 120°F (-40°C to 50°C)
<b>Operation</b>	41°F to 95°F (5°C to 35°C) with up to 80% humidity non-condensing

---

## SMART Order Number

<b>SB690</b>	94 1/4" diagonal (239.3 cm) diagonal SMART Board interactive whiteboard
--------------	-------------------------------------------------------------------------

**Optional Accessories**

<b>Part Number</b>	<b>Description</b>	<b>NA</b>	<b>UK</b>	<b>EU</b>	<b>AU</b>
<b>RS232-XX*</b>	RS-232 to USB conversion module that allows a serial connection to the interactive whiteboard as an alternative to USB	✓	✓		
<b>WC6-XX*</b>	Wireless Bluetooth® connection between the SMART Board interactive whiteboard and the computer	✓	✓		
<b>SBA-XX*</b>	USB audio system with two 15 W speakers that mount to the interactive whiteboard or wall	✓	✓		✓
<b>SYSON6-XX*</b>	SystemOn expansion module wakes up the computer and turns on the projector with one button press	✓	✓		
<b>USB-GW</b>	GoWire™ SMART Board software auto-launch USB cable				
<b>USB-XT</b>	16' (5 m) USB active extension cable				
<b>CAT5-XT</b>	USB to Cat 5 cable extender set				
<b>RPEN-ER</b>	Replacement set of four pen tray pens (black, red, blue and green) and rectangular eraser				
<b>RPEN</b>	Replacement set of four pen tray pens (black, red, blue and green)				

\* Part numbers ending in XX have power supplies for those countries or regions, as indicated by ✓ in the columns to the right. When ordering, substitute the XX in the part number with the country code as follows:

- NA = Canada and U.S.
- UK = United Kingdom
- EU = European Union
- AU = Australia

**SMART Technologies Inc.**  
 1207 – 11 Avenue SW, Suite 300  
 Calgary, AB T3C 0M5  
 CANADA



[www.smarttech.com/support](http://www.smarttech.com/support) [www.smarttech.com/contactsupport](http://www.smarttech.com/contactsupport)  
 Support +1.403.228.5940 or Toll Free 1.866.518.6791 (Canada/U.S.)

# SMART Board™ Interactive Whiteboard

## Specifications – Model 690

Leave at least 5/8" (1.6 cm) headroom to wall mount the interactive whiteboard

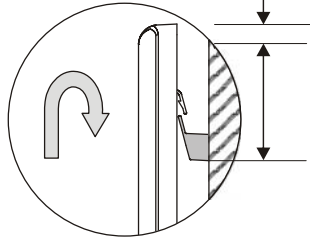

Distance from the bottom of the wall mount bracket to the top of an installed interactive whiteboard is 4 1/4" (10.8 cm)

**Wall-Mounted  
Cut Away View**

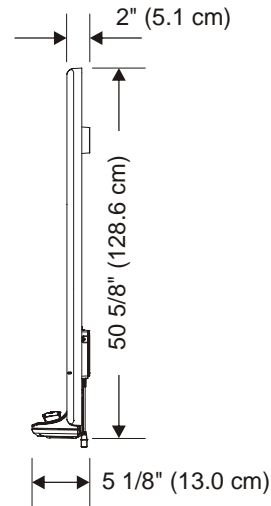

**Wall-Mounted  
Side View**

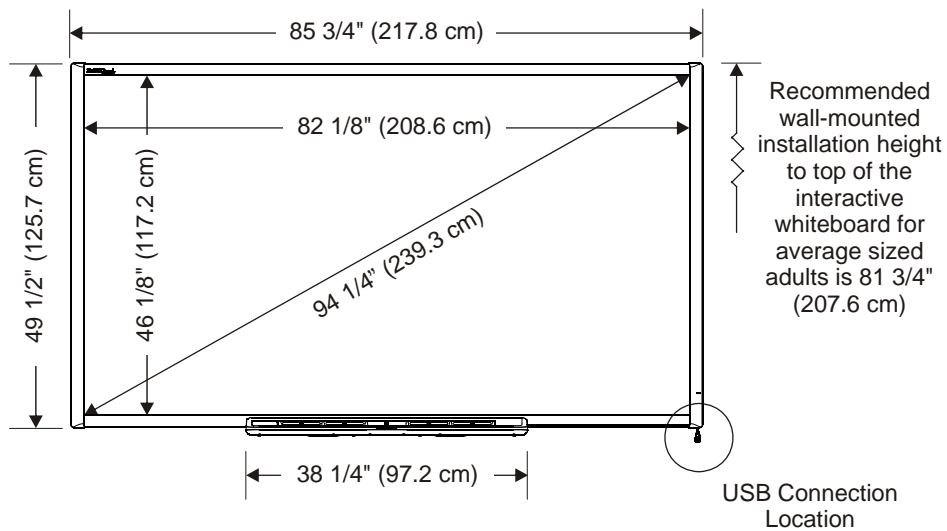

**Wall-Mounted  
Front View**



All dimensions +/- 1/8" (0.3 cm)